

SPECIALTY BEVERAGE SOLUTIONS

Feature Equipment

Oatmeal Express

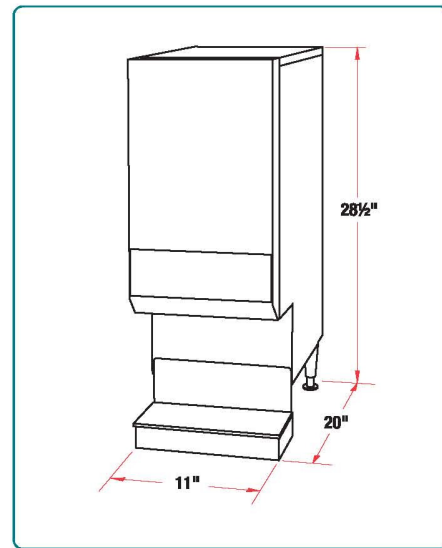

Model GB3 LPO

Features

- **Compact, Space-Saving Size.** Satisfy the growing demand for oatmeal in just 11" of counter space.
- **Easy to Fill, Dispense and Clean.**
- **Direct Drive Auger System.** Ensures perfect hopper alignment and "silent running."
- **Quick Change Transparency.** Simply lift up two tabs and pull out the graphic.
- **Adjustable Drip Tray Height.** To accommodate various cup sizes.
- **Easy to Adjust Temperature Settings.**

Specifications

| Model | Description | Hoppers | Water Tank Capacity | Dimensions (H x W x D) | Electrical | Ship Weight |
|---------|--------------------------|---|--------------------------|--|--------------------|--------------------|
| GB3 LPO | 3-head oatmeal dispenser | Quantity: 3 Capacity: 4 lb (1.8 kg) each | 2.75 gallons (10.4 L) | 28.5" x 11" x 20" (72 cm x 28 cm x 51 cm) | 120V, 1.8 KW, 15 A | 75 lbs. (34 kg) |

Electrical: Line cord included, Nema plug 5-15P.



Specialty Beverage Solutions

Unit B-16, 6020 - 2 Street SE, Calgary, AB T2H 2L8

phone: 888.805.5528 | fax: 888.805.5541 | email: sales@SBSolutions.ca | www.SBSolutions.ca